

SC

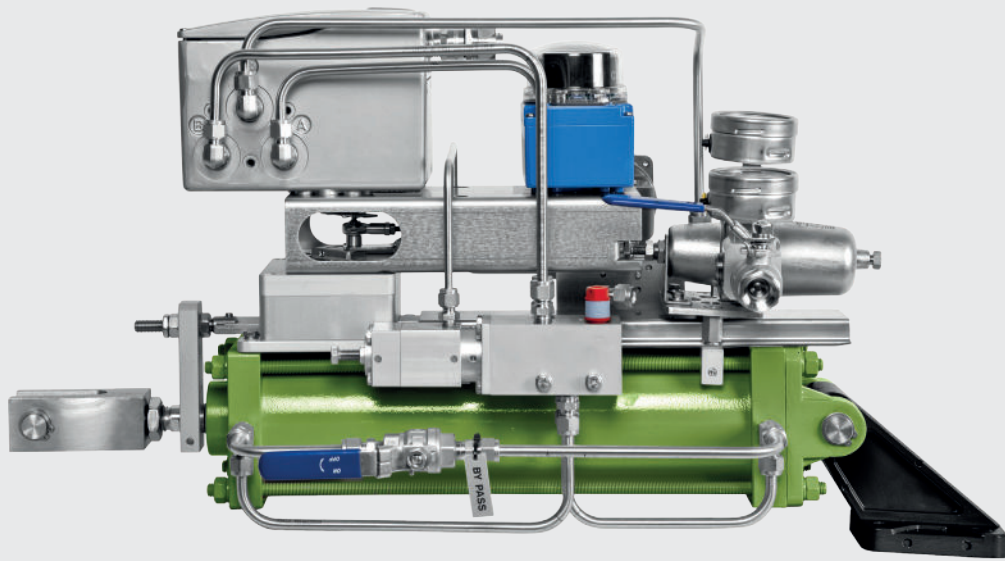

Engineering
GREAT Solutions

Linear Damper Actuators

SC: Linear Damper Actuators

SC is a complete line of linear pneumatic actuators from IMI STI purposely designed and manufactured for the operation of flow control devices such as dampers, louvres, butterfly and ball valves. Thanks to their design, they are ideal for applications in power plants, refineries, pipe works and on board vessels. The range of products includes double acting units and are available in different sizes.

Key features

- > Option to assemble only one positioner independently of stroke
- > Different materials available for any work environment
- > Compact execution with air-lock device in one single component
- > Suitable for power plants, refineries, pipe steel works and on board vessels
- > Available in different sizes (63mm to 420mm)
- > High speed design also available
- > Can be provided with gearbox for emergency manual operation
- > Linkages for coupling to control device are customisable
- > Corrosion resistant alloy for below 160mm
- > Fabricated steel cylinder for 160mm and above
- > Customisation with any accessories on customer request

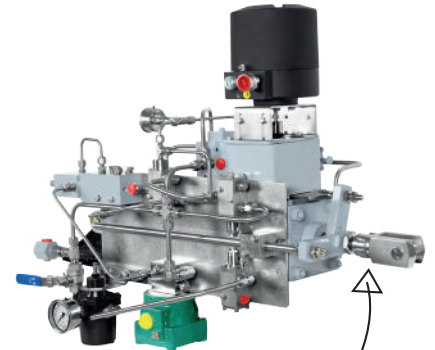

Total capability in valve actuation



Customized control panels can also be designed and manufactured according to any specific needs for remote operation.

Benefits

- > Suitable for harsh environments such as desert areas and petrochemicals plants
- > Light and functional design allows for easy installation
- > Built in lubrication system makes it virtually maintenance free
- > Cylinder can be standard or special strokes
- > Double guide for piston and bushing
- > No dead volume is left in the actuator chamber in fully open or closed positions minimising risk of overshoot
- > Excellent response times without need for boosters



Virtually maintenance free thanks to built in lubrication system

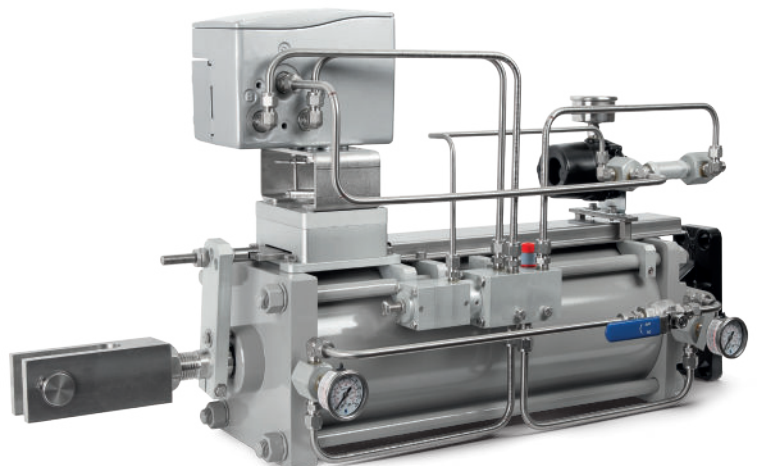

Actuator with piston built-in permanent lubrication system

The SC series of actuators are provided with a built-in permanent lubrication system, patented by IMI STI, which assures an extremely smooth valve operation even if dry instrument air is used. Thanks to this lubrication system, which is common to all IMI STI actuators, no maintenance to moving parts is required, even after many years of continuous service.

The patented lubrication system consists mainly of a grease lubricant filled annular

cavity placed inside the cylinder piston, between a sealing ring and a sliding ring to avoid direct contact between the metal surfaces of the piston and the cylinder, even in case of lateral forces acting on the actuator stem; the grease in the annular cavity, keeps the metal parts lubricated during piston movement allowing very smooth sliding and a long seal life.

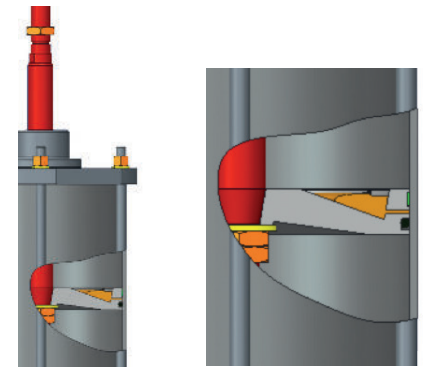

Technical specifications

Operating pressure

Pneumatic version up to 10 barg
(special version available on request)

Standard operating temperature

-20°C to 70°C (lower or higher temperature on request)

Cylinder

Aluminum alloy for Ø 63 to 100 Carbon steel for Ø 125 to 420 (Chrome or nickel plated)

Caps

Aluminum alloy for Ø 63 to 260
Carbon steel for Ø 330 to 420

Piston

Aluminum alloy for Ø 63 to 260
Carbon steel for Ø 330 to 420

Shaft

Chromium plated alloy steel

Certifications/approvals

PED 2014/68/EU
ATEX 2014/34/EU
EAC TR TS 012/2011
IP66 according to IEC/EN 60529
Further certifications are available, please contact IMI STI for updated list.

Product specifications

1 SC actuator size mm	2 Standard stroke mm	3 Active Area mm ²	4 Thrust at 0,5 MP air supply pressure N
63	150, 200, 250, 300	2800	1400
100	150, 200, 250, 300	7400	3700
125	150, 200, 250, 300	11500	5750
160	150, 200, 250, 300	19300	9650
200	150, 200, 250, 300	30000	15000
260	150, 200, 250, 300	51000	25500
330	150, 200, 250, 300	83600	41800
390	150, 200, 250, 300	117000	58500
420	150, 200, 250, 300	136000	68000

The table shows the main characteristics of SC actuators and the various stroking times which can be obtained in modulation and emergency. Column 1 states the actuator size while column 2 shows the actuator standard stroke.

Other stroke lengths are available on request and may be achieved by using a standard stroke cylinder with an additional internal spacer or by manufacturing the cylinder according to the requested stroke.

Column 3 states active area of each type of actuator while column 4 shows the thrust developed by the each actuator at 0,5 Mpa air supply pressure.

Further information and specific technical support may be obtained by contacting IMI STI sales organization.

Optional accessories

IMI STI designs and produces a wide range of accessories and control systems to ensure superior performance and to satisfy the most demanding requirements in modulating, on/off and heavy duty service. Control systems pan-els/cabinets can be installed on the actuators or supplied loose for remote mounting which allows for easy access and limits exposure to excess heat and vibration. For more information, see dedicated brochure of accessories.

IMI STI - Headquarters

Via Dei Caravaggi 15
24040 Levate (BG)
Italy

Tel. +39 035 2928.2
Fax +39 035 2928.247

IMI STI - Quarter Turn Division

Via San Francesco 18
29017 Fiorenzuola d'Arda (PC)
Italy

Tel. +39 035 2928.2
Fax +39 0523 1715.295

IMI Critical Engineering

Lakeside, Solihull Parkway
Birmingham Business Park
Birmingham B37 7XZ
United Kingdom

Tel: +44 (0)121 717 3700
Fax: +44 (0)121 717 3701

www.imi-critical.com
imisti.sales@imi-critical.com

